

12 Volt Load Control for Electric Brake Systems No. 1300-78

P-1385
819-0128

Installation Instructions



The Warner Electric Load Control provides the capability to properly proportion the braking power of the trailer brakes to the trailer weight. The Load Control is a variable resistor which allows the operator to reduce current flow to the trailer brakes by turning the control knob. Depending on road conditions and trailer load, the knob can be set at any position between "MIN BRAKE" and "MAX BRAKE". The Load Control provides a broad range of adjustment to suit a wide variety of operating conditions.

⚠ WARNING Failure to follow these instructions may result in product damage, equipment damage, and serious or fatal injury to personnel.

Specifications

Resistance Rating: 0-5 ohms

Voltage: 12 volts DC
(use only with 12 volt system)

Brake Coil: Designed for 2-4 brakes wired in parallel, each with 3.0-3.5 ohms coil resistance.

Installation

Mounting the Control

The Load Control should be mounted under or behind the towing vehicle's instrument panel to the left or right of the steering column, depending on available space and driver preference.

To mount the Load Control, sit in a normal driving position and place the Control case so its knob is within easy reach. (See Figure 1)

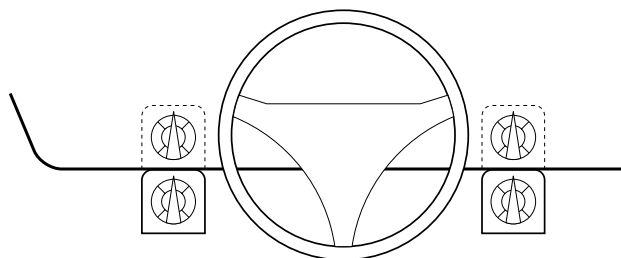

Mount on either side

Figure 1

For under-dash mounting proceed as follows:

1. While holding the Load Control case in position, mark the underside of the instrument panel through the two mounting holes in the case.
2. Drill two 13/64" diameter holes where marked, being careful not to damage anything under the instrument panel.

For behind instrument panel mounting proceed as follows:

1. Position the face of the Load Control shaft hole and the washer projection hole.
2. Drill a 13/32" diameter hole for the Load Control shaft and a 3/16" diameter hole for the washer projection, where marked. Be careful not to damage anything under the instrument panel.

Electrical Connection

The Load Control is to be wired in series with the electric brake controller and the trailer brakes. Refer to the "Typical Wiring Diagram" to connect the Load Control into the brake system. (See Figure 2)

Typical Wiring Diagram
Warner Load Control 1300-78

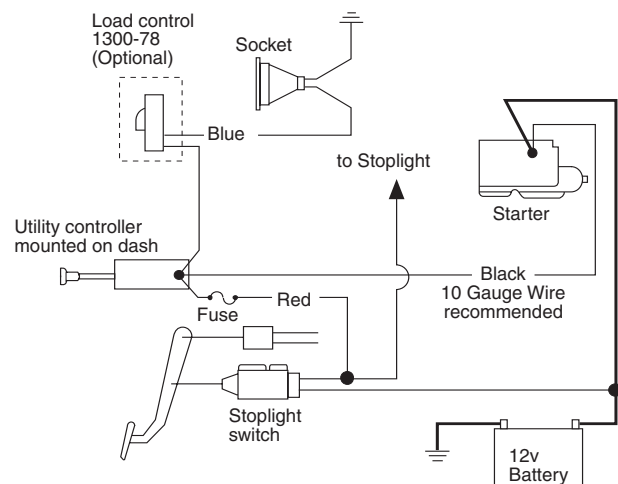

Figure 2

Note: Use only 10 or 12 gauge wire meeting SAE Specification J558a for connecting the Load Control.

Strip the insulation back about 1/4" from each cut end. Insert one stripped end into each of the two insulated ring terminals provided. After inserting the full length of bared wire, crimp the terminal using AMP hand tool 59239-4 (G9150-7 for thin-wall insulation) or equivalent. Assemble the wired terminals to the Load Control, but do not tighten. One lead is to be attached to the center terminal, the other to the left hand (heavy resistance wire side of the resistor) terminal when facing the rear of the resistor. (See Figure 3)

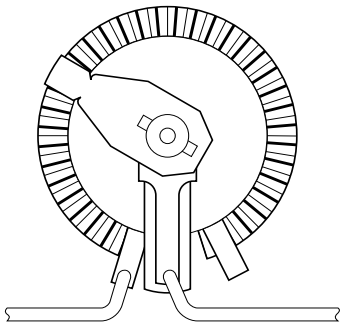

Figure 3

Under Instrument Panel Installation

Mount the case under the instrument panel, inserting the tapping screws (with heads inside the control case) provided through the newly-drilled holes and tightening securely to the speed-nuts included with your Load Control.

Remove the jam nut from the Load Control shaft and insert the shaft and the washer projection into the holes provided in the front portion of the case.

Place the Load Control into the case so the washer projection protrudes through the case front. Position the dial face on the case and tighten the jam nut securely with the washer locating tab projecting through its locator hole. Assemble the hand knob to the control shaft, positioning it so the knob screw opposite the pointer sets against the control shaft flat. Tighten the setscrews securely. Tighten both electrical terminal connections, carefully positioning the lead wires so the ring terminals will not contact the sides of the case.

Behind Instrument Panel Installation

Remove the jam nut from the Load Control shaft and insert the shaft and the washer projection into the holes provided in the front portion of the case.

Insert the Load Control into its case so the washer locating tab protrudes through the case front. Insert the control shaft and locating tab into the holes provided in the instrument panel. Position the dial face on the control shaft and tighten the jam nut securely with the washer locating tab projecting through the case instrument panel, and dial face. Assemble the hand knob to the control shaft, positioning it so the knob setscrew opposite the pointer sets against the control shaft flat. Tighten the setscrew securely. Tighten both electrical terminal connections, carefully positioning the lead wires so the ring terminals will not contact the sides of the case.

Since the Load Control can become very warm during normal operation, the case must be used with the control whether it is mounted under or behind the instrument panel. When installing the Load Control, take care to assure that all electrical wires and other underdash components are securely fastened to prevent accidental contact with the resistor winding.

Adjustment

Your Warner Electric Load Control will help compensate for trailer load variations by limiting the maximum torque output of the brakes by adding dropping resistance in the electrical control line. When towing a trailer loaded to brake rated capacity, the Load Control must be set at maximum braking. When pulling an empty or partially loaded trailer, the Load Control must be set between maximum and minimum braking at a position just before the point at which trailer tire skidding occurs when actuating the hand control fully on. Failure to use the Warner Electric Load Control properly can result in excessive brake torque when stopping a trailer loaded to less than brake capacity.

Warranty

Warner Electric LLC warrants that it will repair or replace (whichever it deems advisable) any product manufactured and sold by it which proves to be defective in material or workmanship within a period of one (1) year from the date of original purchase for consumer, commercial or industrial use.

This warranty extends only to the original purchaser and is not transferable or assignable without Warner Electric LLC's prior consent.

Warranty service can be obtained in the U.S.A. by returning any defective product, transportation charges prepaid, to the appropriate Warner Electric LLC factory. Additional warranty information may be obtained by writing the Customer Satisfaction Department, Warner Electric LLC, 449 Gardner Street, South Beloit, Illinois 61080, or by calling 815-389-3771.

A purchase receipt or other proof of original purchase will be required before warranty service is rendered. If found defective under the terms of this warranty, repair or replacement will be made, without charge, together with a refund for transportation costs. If found not to be defective, you will be notified and, with your consent, the item will be repaired or replaced and returned to you at your expense.

This warranty covers normal use and does not cover damage or defect which results from alteration, accident, neglect, or improper installation, operation, or maintenance.

Some states do not allow limitation on how long an implied warranty lasts, so the above limitation may not apply to you.

Warner Electric LLC's obligation under this warranty is limited to the repair or replacement of the defective product and in no event shall Warner Electric LLC be liable for consequential, indirect, or incidental damages of any kind incurred by reason of the manufacture, sale or use of any defective product. Warner Electric LLC neither assumes nor authorizes any other person to give any other warranty or to assume any other obligation or liability on its behalf.

WITH RESPECT TO CONSUMER USE OF THE PRODUCT, ANY IMPLIED WARRANTIES WHICH THE CONSUMER MAY HAVE ARE LIMITED IN DURATION TO ONE YEAR FROM THE DATE OF ORIGINAL CONSUMER PURCHASE. WITH RESPECT TO COMMERCIAL AND INDUSTRIAL USES OF THE PRODUCT, THE FOREGOING WARRANTY IS IN LIEU OF AND EXCLUDES ALL OTHER WARRANTIES, WHETHER EXPRESSED OR IMPLIED BY OPERATION OF LAW OR OTHERWISE, INCLUDING, BUT NOT LIMITED TO, ANY IMPLIED WARRANTIES OF MERCHANTABILITY OR FITNESS.

Some states do not allow the exclusion or limitation of incidental or consequential damages, so the above limitation or exclusion may not apply to you. This warranty gives you specific legal rights and you may also have other rights which vary from state to state.

Changes in Dimensions and Specifications

All dimensions and specifications shown in Warner Electric catalogs are subject to change without notice. Weights do not include weight of boxing for shipment. Certified prints will be furnished without charge on request to Warner Electric.



Warner Electric LLC
449 Gardner Street • South Beloit, IL 61080
815-389-3771 • Fax: 815-389-2582
www.warnerelectric.com